

Mathematical studies
Standard level
Paper 2

Tuesday 13 November 2018 (morning)

1 hour 30 minutes

Instructions to candidates

- Do not open this examination paper until instructed to do so.
- A graphic display calculator is required for this paper.
- A clean copy of the **mathematical studies SL formula booklet** is required for this paper.
- Answer all the questions in the answer booklet provided.
- Unless otherwise stated in the question, all numerical answers should be given exactly or correct to three significant figures.
- The maximum mark for this examination paper is **[90 marks]**.

Blank page

Answer **all** questions in the answer booklet provided. Please start each question on a new page. You are advised to show all working, where possible. Where an answer is incorrect, some marks may be given for a correct method, provided this is shown by written working. Solutions found from a graphic display calculator should be supported by suitable working, for example, if graphs are used to find a solution, you should sketch these as part of your answer.

1. [Maximum mark: 14]

The marks obtained by nine Mathematical Studies SL students in their projects (x) and their final IB examination scores (y) were recorded. These data were used to determine whether the project mark is a good predictor of the examination score. The results are shown in the table.

Project mark (x)	10	18	14	18	10	18	6	18	14
Examination score (y)	47	61	61	47	54	68	47	54	47

- (a) Use your graphic display calculator to write down
- (i) \bar{x} , the mean project mark;
 - (ii) \bar{y} , the mean examination score;
 - (iii) r , Pearson’s product–moment correlation coefficient. [4]

The equation of the regression line y on x is $y = mx + c$.

- (b) (i) Find the exact value of m and of c for these data.
- (ii) Show that the point $M(\bar{x}, \bar{y})$ lies on the regression line y on x . [4]

A tenth student, Jerome, obtained a project mark of 17.

- (c) (i) Use the regression line y on x to estimate Jerome’s examination score.
- (ii) Justify whether it is valid to use the regression line y on x to estimate Jerome’s examination score. [4]

In his final IB examination Jerome scored 65.

- (d) Calculate the percentage error in Jerome’s estimated examination score. [2]

Turn over

2. [Maximum mark: 14]

160 students attend a dual language school in which the students are taught only in Spanish or taught only in English.

A survey was conducted in order to analyse the number of students studying Biology or Mathematics. The results are shown in the Venn diagram.

Set S represents those students who are **taught** in Spanish.

Set B represents those students who **study** Biology.

Set M represents those students who **study** Mathematics.



(a) Find the number of students in the school that

- (i) are taught in Spanish;
- (ii) study Mathematics in English;
- (iii) study both Biology and Mathematics.

[6]

(This question continues on the following page)

(Question 2 continued)

(b) Write down

(i) $n(S \cap (M \cup B))$;

(ii) $n(B \cap M \cap S')$. [2]

A student from the school is chosen at random.

(c) Find the probability that this student

(i) studies Mathematics;

(ii) studies neither Biology nor Mathematics;

(iii) is taught in Spanish, given that the student studies Biology. [6]

Turn over

3. [Maximum mark: 16]

The final examination results obtained by a group of 3200 Biology students are summarized on the cumulative frequency graph.

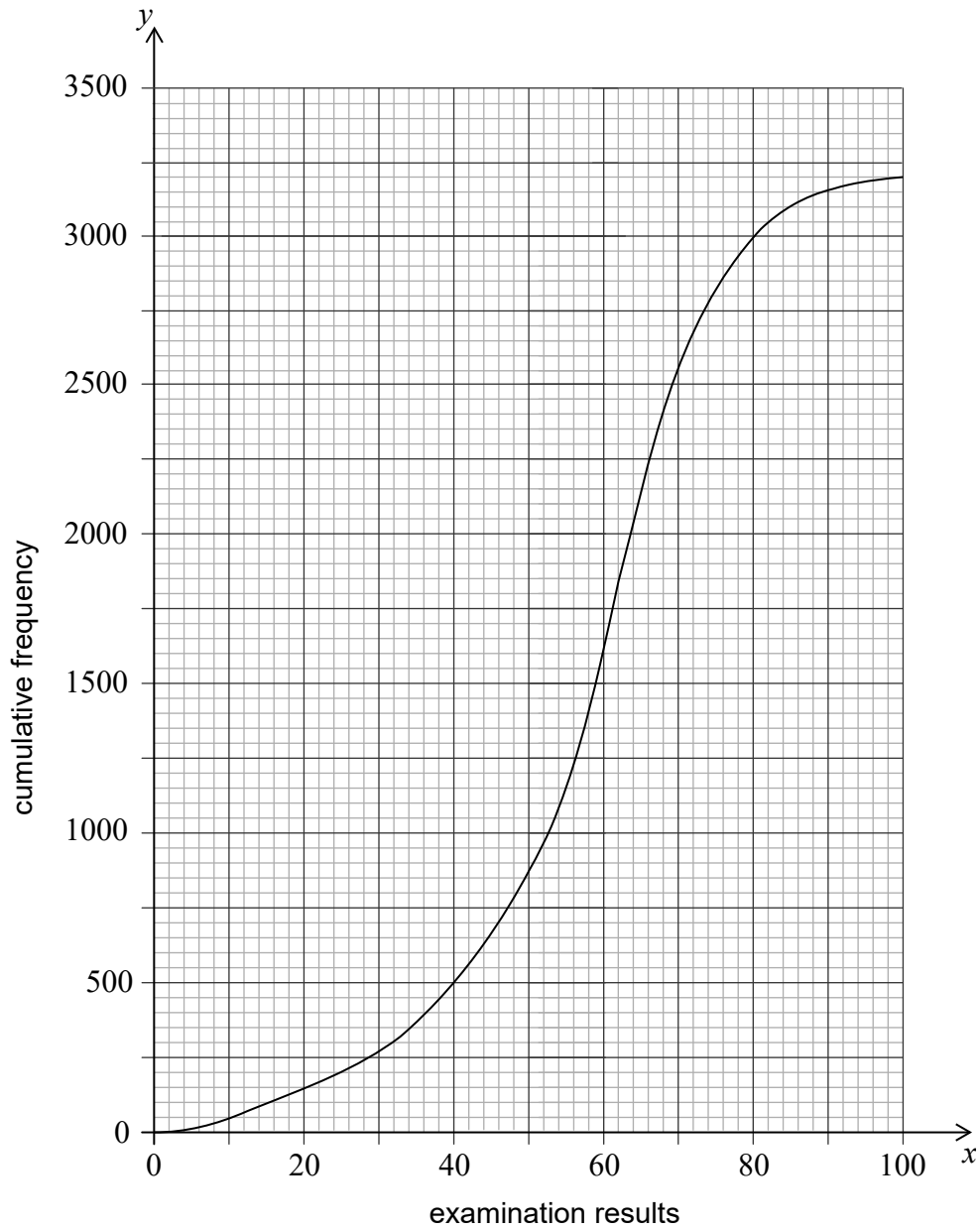

(a) Find

(i) the median of the examination results;

(ii) the interquartile range.

[5]

350 of the group obtained the highest possible grade in the examination.

(b) Find the final examination result required to obtain the highest possible grade.

[2]

(This question continues on the following page)

(Question 3 continued)

The grouped frequency table summarizes the examination results of this group of students.

Examination result (x)	$0 < x \leq 20$	$20 < x \leq 40$	$40 < x \leq 60$	$60 < x \leq 80$	$80 < x \leq 100$
Frequency	150	350	1100	1400	200

- (c) Write down
 - (i) the modal class;
 - (ii) the mid-interval value of the modal class. [3]
- (d) Calculate an estimate of
 - (i) the mean examination result;
 - (ii) the standard deviation, giving your answer correct to **three decimal places**. [3]

The teacher sets a grade boundary that is one standard deviation below the mean.

- (e) Use the cumulative frequency graph to estimate the number of students whose final examination result was below this grade boundary. [3]

Turn over

4. [Maximum mark: 13]

Consider the function $f(x) = \frac{27}{x^2} - 16x$, $x \neq 0$.

- (a) Sketch the graph of $y = f(x)$, for $-4 \leq x \leq 3$ and $-50 \leq y \leq 100$. [4]
- (b) Use your graphic display calculator to find
 - (i) the zero of $f(x)$;
 - (ii) the coordinates of the local minimum point;
 - (iii) the equation of the tangent to the graph of $y = f(x)$ at the point $(-2, 38.75)$.
Give your answer in the form $y = mx + c$. [5]
- (c) Sketch the graph of the function $g(x) = 10x + 40$ on the same axes. [2]
- (d) Solve the equation $f(x) = g(x)$. [2]

5. [Maximum mark: 15]

A flat horizontal area, ABC , is such that $AB = 100\text{ m}$, $BC = 50\text{ m}$ and angle $\hat{ACB} = 43.7^\circ$ as shown in the diagram.

diagram not to scale

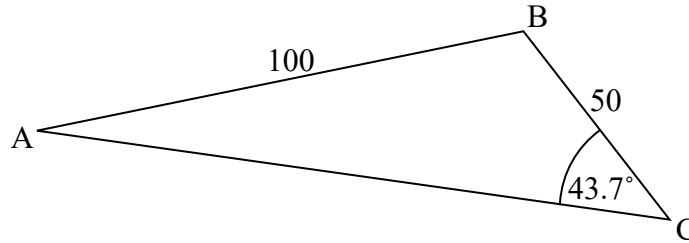

- (a) Show that the size of angle \hat{BAC} is 20.2° , correct to 3 significant figures. [3]
- (b) Calculate the area of triangle ABC . [4]
- (c) Find the length of AC . [3]

A vertical pole, TB , is constructed at point B and has height 25 m .

- (d) Calculate the angle of elevation of T from, M , the midpoint of the side AC . [5]

Turn over

6. [Maximum mark: 18]

Haruka has an eco-friendly bag in the shape of a cuboid with width 12 cm, length 36 cm and height of 9 cm. The bag is made from five rectangular pieces of cloth and is open at the top.

diagram not to scale

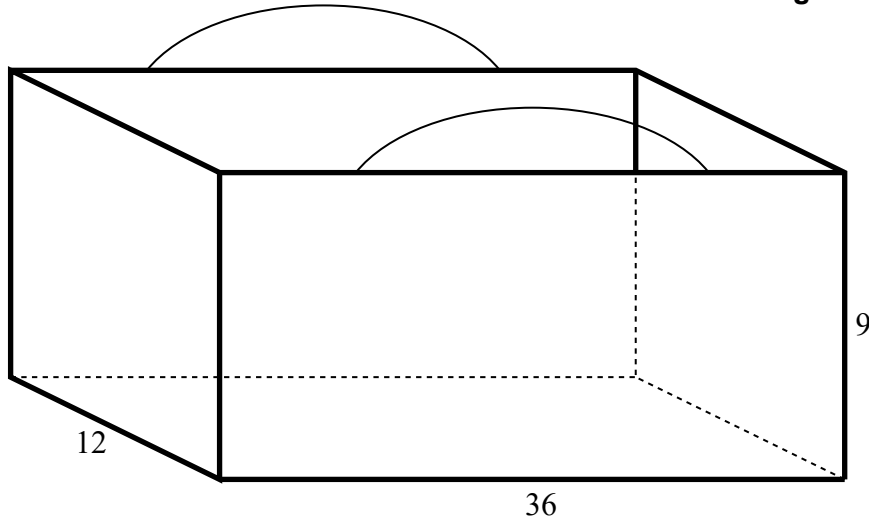

(a) Calculate the area of cloth, in cm^2 , needed to make Haruka's bag. [2]

(b) Calculate the volume, in cm^3 , of the bag. [2]

(This question continues on the following page)

(Question 6 continued)

Nanako decides to make her own eco-friendly bag in the shape of a cuboid such that the surface area is minimized.

The width of Nanako's bag is x cm, its length is three times its width and its height is y cm.

diagram not to scale

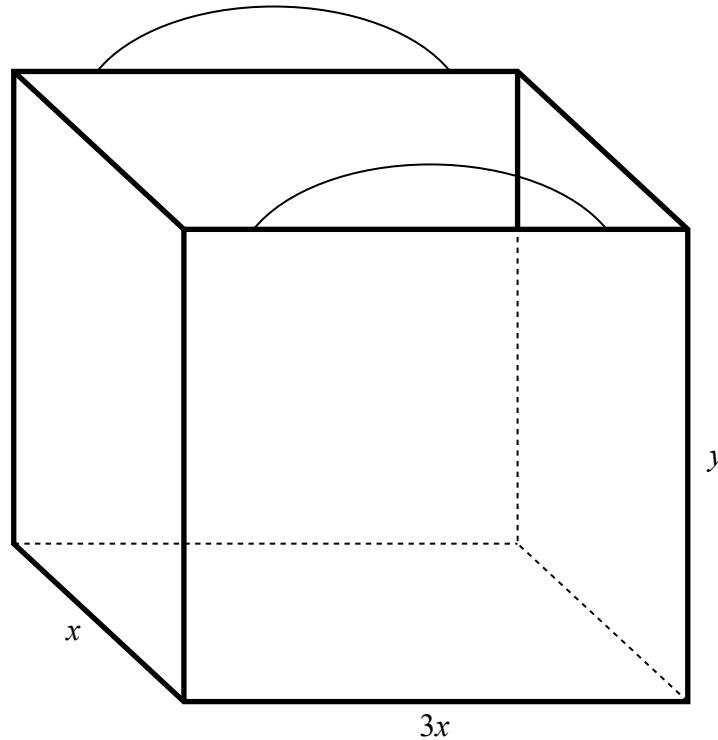

The volume of Nanako's bag is 3888 cm^3 .

(c) Use this value to write down, and simplify, the equation in x and y for the volume of Nanako's bag. [2]

(d) Write down and simplify an expression in x and y for the area of cloth, A , used to make Nanako's bag. [2]

(e) Use your answers to parts (c) and (d) to show that

$$A = 3x^2 + \frac{10368}{x}. \quad [2]$$

(f) Find $\frac{dA}{dx}$. [3]

(g) Use your answer to part (f) to show that the width of Nanako's bag is 12 cm. [3]

The cloth used to make Nanako's bag costs 4 Japanese Yen (JPY) per cm^2 .

(h) Find the cost of the cloth used to make Nanako's bag. [2]